

#PTA-422

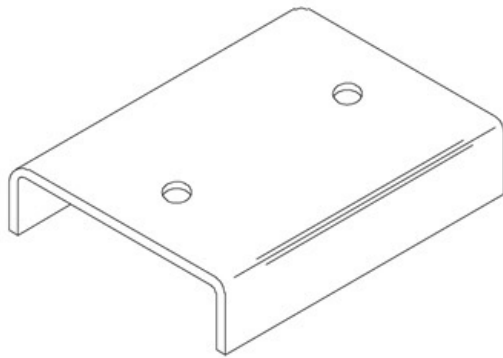

#PTA-422

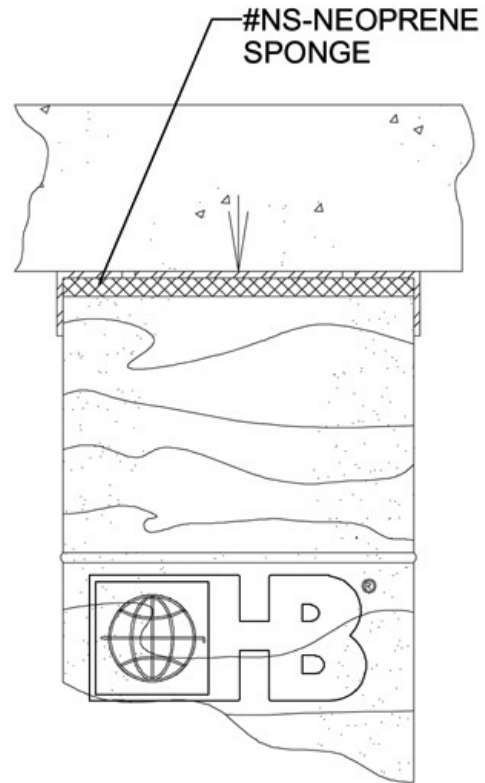

DRAWINGS FOR ILLUSTRATIVE PURPOSES ONLY

<p>SHEET METAL (Carbon Steel): ASTM A 366/A 366M (Cold-rolled) ASTM A 569 (Hot-rolled, pickled and oiled)</p> <p>FINISHES - SHEET METAL (Carbon Steel): Mill Galvanized - ASTM A 653 Coating Designation G60 Hot-Dip Galvanized - ASTM A 153 Class B (sheet metal ties and anchors hot-dip galvanized after fabrication) Note: Hohmann & Barnard will certify to a minimum zinc coating of 2.0 oz./ft.²</p> <p>SHEET METAL (Stainless Steel): ASTM A 167 - AISI Type 304 Stainless Steel (sheet metal ties and anchors) (Type 316 available on special order) Note: H&B recommends Stainless Steel for maximum protection against corrosion.</p>	<p>FINISHES:</p> <ul style="list-style-type: none"> <input type="checkbox"/> Mill galvanized <input type="checkbox"/> Hot-dip galvanized <input type="checkbox"/> Stainless Steel <p>NOTE: #NS-Neoprene Sponge also available. Submittal sheet available on request.</p>
---	---



Hohmann & Barnard, Inc.
 30 Rasons Court
 Hauppauge, New York 11788
 TEL: (800) 645-0616 FAX: (631) 234-0683

WEBSITE: www.h-b.com
 E-MAIL: weanchor@h-b.com